



## Real home theatre

If your home theatre installation is in need of inspiration, look no further. This is the control room of the scoring stage at Skywalker Sound, George Lucas' state-of-the-art audio production facility in Marin County, California. It's where major studios come to record award-winning soundtracks for hit movies. The control room is probably the ultimate multi-channel listening environment, conveying sound to the most discerning ears in the film business. You can emulate the audio quality of

Skywalker Sound and dozens of other professional studios in your own home theatre installation. Skywalker's speakers are from the 800 Series by Bowers & Wilkins, a range whose stunning sound quality has drawn praise from professionals worldwide. Custom Theatre 800 combines the extraordinary clarity, depth and control of the 800 Series with the capability of much higher sound pressure levels, and a cabinet design that can be integrated into the structure of your theatre room.

With a B&W Custom Theatre system in place, studio-quality sound will seep and surge from the sides of your room. It brings movie sound intact, from where it's made to where it's meant to be heard.



# Custom Theatre 800

## Surround speaker: CT8 DS

A typical CT800 installation will feature two or more vertical surround sound speakers at the rear and sides to generate an authentically three-dimensional listening experience. To maximise the 3D effect, the CT8 DS incorporates additional side-firing midrange drivers for the option of dipole operation.

## Front speaker: CT8 LR

Stationed to the left and right of the screen are two upright speakers. The CT8 LR features a spherical midrange/tweeter head that can be tilted towards the listener to retain a focused delivery, plus twin 10" bass units, as in the surround speaker.

## Centre speaker: CT8 CC

The centre speaker has the identical driver complement to the CT8 LR for precise timbre matching, but rearranged to suit its horizontal orientation. Shown here positioned below the screen, it could equally well be placed above, thanks to the adjustable midrange/tweeter head.

## Subwoofer: CT8 SW

Integral to the system's no-compromise approach to bass management is the subwoofer, illustrated here with a pair deployed at extreme left and right for low frequencies that will push your sound envelope to the limit. The CT8 SW features a 15" driver. Like all the bass drivers in the range it features a rigid composite sandwich cone.



A CT800 system allows you to create your own private cinema in the comfort of your home. At the movies, no-one notices the speakers; they just notice the sound – every last whisper, creak, pitter-patter and pin-drop. It's the same when you custom-build your own viewing room around the CT800 range. We haven't compromised a single decibel on the sound quality – the system is actually more powerful than most conventional competitors – and yet, once installed, the speakers can be virtually invisible. Angle-adjustable midrange and tweeter drive units give you flexibility to hide the speakers, yet maintain the full quality of the sound as it fills the room.



# Performance of a lifetime

The performance of a CT800 system will beat any cinema or home theatre sound system you might have heard before. Each speaker is a harmony of advanced audio technologies and craftsmanship that has taken years of painstaking work to perfect. The starting point was the phenomenal Nautilus™ speaker (bottom left), which threw the rulebook of speaker design out of the window and took an intensive five-year programme to develop. The philosophies and technologies of Nautilus™ were inherited by the B&W 800 Series, our top-of-the-range hifi speakers. Now they have been developed further for use in a customised home theatre setting.

For example, the teardrop-shaped tube of the 800 Series midrange unit, plus the tweeter and its tube, have been folded into a damped aluminium sphere (below). This sits inside the cabinet like an eye in a socket and can be swivelled towards the listener for maximum focus. We have introduced active bass operation for all models, boosting the delivery of low frequency effects and allowing the bass output of the system to be structured according to the dimensions and acoustics of your own room. We've put a lot into our Custom Theatre speakers. They may be the most sophisticated pieces of kit you'll ever keep in a cupboard. And you won't ever want to take them out.

## Active bass

Working with world-leading audio component manufacturer Classé, B&W has developed a bass management system for the CT800 range whose clarity and power will leave you speechless. In conventional home theatre systems, the very low bass from the front and surround channels is often squeezed into a single subwoofer along with the Low Frequency Effects (LFE) channel. Contrast this with a CT800 system, where a subwoofer is actively combined with each of the front left and right channels, so that they are truly full range and preserve directional information to the lowest frequencies as intended. In fact you can assign up to 4 subwoofers to any of the front or surround channels. The single LFE channel is then distributed to all of the speakers, giving a much more natural sensation of space and ambience. Even at very high volumes, the system retains consummate control over its output. All you have to do is hold on to your seat.



## Cabinet bracing

Sound with backbone demands a speaker with backbone. In a system with as much power as this, the physical forces exerted on the cabinet by the air movements inside it are huge. To hold the cabinet walls in place and avoid the kind of vibrations and flexures that can taint the sound, each speaker contains B&W's Matrix™ internal bracing system of interlocking anechoic cells. This indomitable skeleton – like that of a building – dissipates forces around the structure and creates a single rock solid unit.

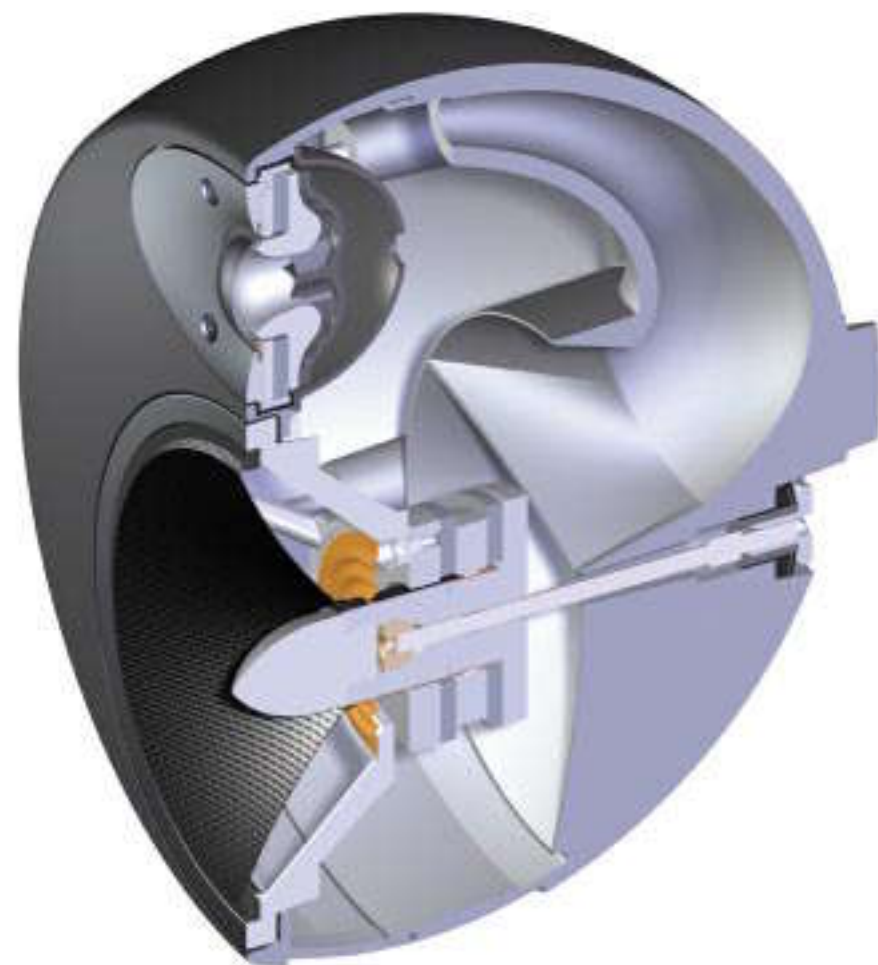

## Tweeter

For the Custom Theatre range we have taken our development of the Nautilus™-derived tube-loaded tweeter a stage further. Following the same principle as our adaptation of the midrange tube (see opposite), we've replaced the single, long tube with a whirl of tightly-packed, smaller channels contained in a shallow cup, each of which absorbs a portion of the unwanted sound energy from the back of the diaphragm. Even at frequencies well beyond human hearing, this tweeter sings like a bird.



## Bass drivers

As you might imagine, one of the secrets of developing a high performance bass driver is finding a cone material with high enough strength to keep its shape under the heaviest of strain, yet not too heavy that it loses its responsiveness. Our choice is Rohacell® a modern carbon fibre and rigid foam sandwich construction used in car and aircraft bodies. Its outstanding mechanical properties and relatively low mass make it tailor-made for the job of turning low frequency effects into real-life sound.



## Midrange

Some things don't change. For 25 years Kevlar® has been outperforming pretenders to its position as the number one material for midrange driver cones. Its woven structure resists the concentric standing waves that blur the sound from conventional cones, and presents the most immediate parts of the sound spectrum in all their true colours. Lending support is B&W's FST™ technology: a foamed polymer surround that mirrors the mechanical properties of the Kevlar®, absorbing residual resonances and bending waves in the cone. A formidable partnership.



## Crossover

The better the mechanical design of a speaker, the simpler the electronic design can be. The passive part of the CT800's crossover uses the same high quality circuitry that we developed for the 800 Series: the critical tweeter and midrange drivers being 1st-order, the simplest circuit possible. That simplicity, coupled with using components of the highest calibre, helps to retain the purity of the signal.



If the adjustable head unit of the CT8 LR and CT8 CC reminds you of a seashell with its inner chambers and channels, you're halfway to understanding how we preserve the driver's crystal clarity. With the distinctly conch-like Nautilus™ (left), we pioneered the concept of

draining away unwanted excess sound energy that emanates from the rear of a driver by allowing it to disappear into a tapering tube, rather than letting it bounce noisily around inside the cabinet. As the ripple tank (right) demonstrates with water, waves are virtually non-existent

by the time they reach the inner recesses of the curled tube. With the Custom Theatre midrange, we repeated the trick, splaying the tube into three mini-tubes and curling them inside the driver's spherical enclosure.



# Performance of a lifetime

The performance of a CT800 system will beat any cinema or home theatre sound system you might have heard before. Each speaker is a harmony of advanced audio technologies and craftsmanship that has taken years of painstaking work to perfect. The starting point was the phenomenal Nautilus™ speaker (bottom left), which threw the rulebook of speaker design out of the window and took an intensive five-year programme to develop. The philosophies and technologies of Nautilus™ were inherited by the B&W 800 Series, our top-of-the-range hifi speakers. Now they have been developed further for use in a customised home theatre setting.

For example, the teardrop-shaped tube of the 800 Series midrange unit, plus the tweeter and its tube, have been folded into a damped aluminium sphere (below). This sits inside the cabinet like an eye in a socket and can be swivelled towards the listener for maximum focus. We have introduced active bass operation for all models, boosting the delivery of low frequency effects and allowing the bass output of the system to be structured according to the dimensions and acoustics of your own room. We've put a lot into our Custom Theatre speakers. They may be the most sophisticated pieces of kit you'll ever keep in a cupboard. And you won't ever want to take them out.

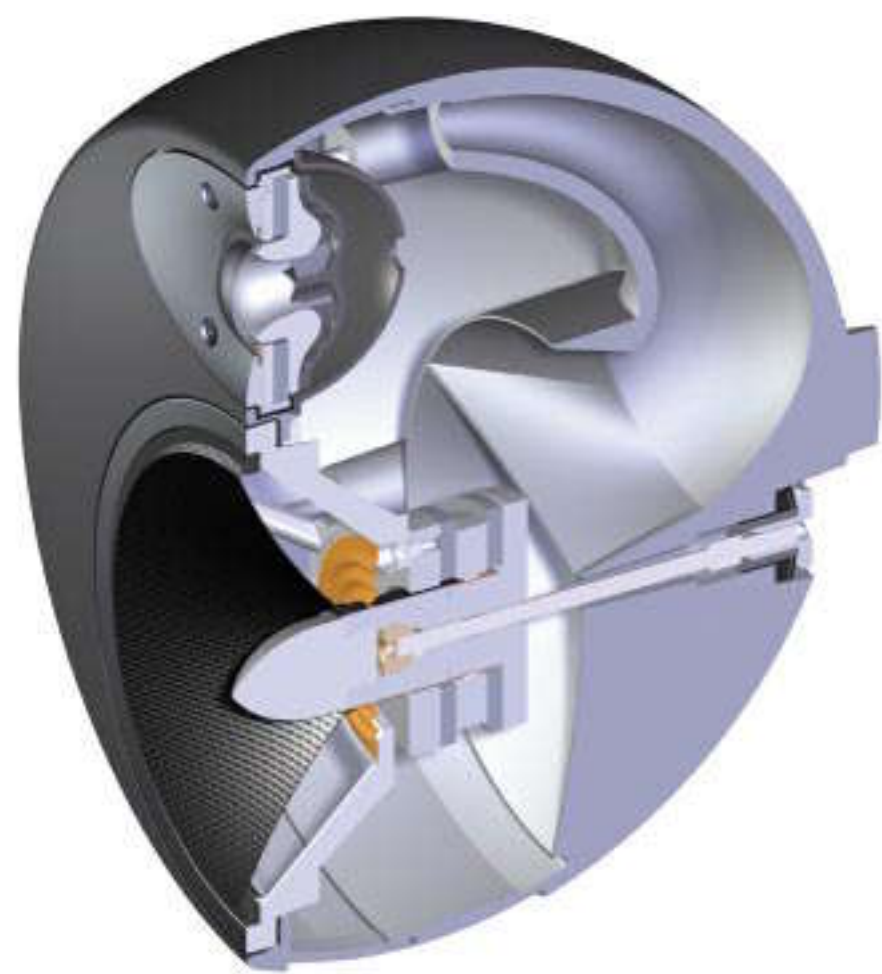

## CT8 LR

Technical features	Adjustable midrange/tweeter head Nautilus™ tweeter Kevlar® brand fibre cone FST™ midrange Rohacell® cone bass units Matrix cabinet Active bass crossover
Description	3-way closed-box system
Drive units	1x ø32mm (1¼ in) metal dome high-frequency 1x ø150mm (6 in) woven Kevlar® cone FST™ midrange 2x ø250mm (10 in) carbon fibre/Rohacell® sandwich cone bass
Frequency range	-6dB at 23Hz and 40kHz
Frequency response	29Hz – 24kHz ±3dB on reference axis
Dispersion	Within 2dB of reference response Horizontal: over 60° arc Vertical: over 10° arc
Sensitivity	93dB spl (2.83V, 1m) (mf/ht)
Harmonic distortion	2nd and 3rd harmonics (90dB, 1m) <1% 45Hz – 20kHz <0.5% 55Hz – 20kHz
Nominal impedance	8Ω (minimum 4Ω)
Crossover frequencies	300Hz, 4kHz
Recommended amplifier power	50W – 1000W into 8Ω on unclipped programme
Max. recommended cable impedance	0.1Ω
Dimensions	Height: 1100mm (43.3 in) (without spike feet) Width: 325mm (12.8 in) Depth: 550mm (21.65 in)
Net weight	85kg (187 lb)
Finishes	Cabinet: Black

## CT8 CC

Technical features	Adjustable midrange/tweeter head Nautilus™ tweeter Kevlar® brand fibre cone FST™ midrange Rohacell® cone bass units Matrix cabinet Active bass crossover
Description	3-way closed-box system
Drive units	1x ø32mm (1¼ in) metal dome high-frequency 1x ø150mm (6 in) woven Kevlar® cone FST™ midrange 2x ø250mm (10 in) carbon fibre/Rohacell® sandwich cone bass
Frequency range	-6dB at 23Hz and 40kHz
Frequency response	29Hz – 24kHz ±3dB on reference axis
Dispersion	Within 2dB of reference response Horizontal: over 60° arc Vertical: over 10° arc
Sensitivity	93dB spl (2.83V, 1m) (mf/ht)
Harmonic distortion	2nd and 3rd harmonics (90dB, 1m) <1% 45Hz – 20kHz <0.5% 55Hz – 20kHz
Nominal impedance	8Ω (minimum 4Ω)
Crossover frequencies	300Hz, 4kHz
Recommended amplifier power	50W – 1000W into 8Ω on unclipped programme
Max. recommended cable impedance	0.1Ω
Dimensions	Height: 325mm (12.8 in) (without spike feet) Width: 1100mm (43.3 in) Depth: 550mm (21.65 in)
Net weight	85kg (187 lb)
Finishes	Cabinet: Black

## CT8 DS

Technical features	Dipole/monopole option with 12V trigger switching Nautilus™ tweeter Kevlar® brand fibre cone FST™ midrange Rohacell® cone bass units Matrix cabinet Active bass crossover
Description	3-way monopole/2-way dipole selectable closed-box surround system
Drive units	1x ø32mm (1¼ in) alloy dome high-frequency 6x ø100mm (4 in) midrange/high-frequency 1x ø150mm (6 in) woven Kevlar® cone FST™ midrange 2x ø250mm (10 in) carbon fibre/Rohacell® sandwich cone bass
Frequency range	-6dB at 26Hz and 40kHz (monopole mode) -6dB at 26Hz and 22kHz (dipole mode)
Frequency response	31Hz – 22kHz ±3dB on reference axis (monopole mode) 31Hz – 18kHz ±3dB power averaged over front hemisphere (dipole mode)
Dispersion	Monopole mode: within 2dB of reference response Horizontal: over 60° arc Vertical: over 10° arc Dipole mode: horizontal figure of eight Effective null zone ±30° (250Hz – 18kHz)
Sensitivity	93dB spl (2.83V, 1m)
Harmonic distortion	2nd and 3rd harmonics (90dB, 1m) <1% 45Hz – 20kHz
Nominal impedance	8Ω (minimum 4Ω)
Crossover frequencies	300Hz and 4kHz (monopole mode) 300Hz (dipole mode)
Recommended amplifier power	50W – 1000W into 8Ω on unclipped programme
Max. recommended cable impedance	0.1Ω
Dimensions	Height: 1100mm (43.3 in) (without spike feet) Width: 325mm (12.8 in) Depth: 250mm (9.85 in)
Net weight	75kg (165 lb)
Finishes	Cabinet: Black Grille: Black cloth

## CT8 SW

Technical features	Rohacell® bass cone Matrix cabinet Active crossover
Description	Closed-box subwoofer
Drive units	1x ø380mm (15 in) carbon fibre/Rohacell® sandwich cone bass
Frequency range	-6dB at 13Hz and 40Hz (using active crossover/equaliser)
Frequency response	18Hz – 35Hz ±3dB on reference axis (using active crossover/equaliser)
Dispersion	Within 2dB of reference response Horizontal: over 90° arc Vertical: over 90° arc
Sensitivity	90dB spl (2.83V, 1m)
Harmonic distortion	2nd and 3rd harmonics (90dB, 1m) <1% 30Hz – 500Hz <0.5% 45Hz – 300Hz
Nominal impedance	8Ω (minimum 4Ω)
Crossover frequency	40Hz
Recommended amplifier power	50W – 1000W into 8Ω on unclipped programme
Max. recommended cable impedance	0.1Ω
Dimensions	Height: 475mm (18.7 in) (without spike feet) Width: 475mm (18.7 in) Depth: 475mm (18.7 in)
Net weight	35kg (77 lb)
Finishes	Cabinet: Black

## CT8 XO

Description	CT800 system active bass management controller
Functions	Bass/midrange crossover Subwoofer/bass crossover Low-frequency roll-off alignment High frequency roll-off alignment Wall proximity response adjustment Subwoofer in/out Level adjustment for number of subwoofers 12V trigger switching for surround mode
Inputs	Line In (XLR & RCA Phono) 12V trigger (3.5mm jack)
Outputs	MF/HF Line Out (XLR & RCA Phono) LF Line Out (XLR & RCA Phono) Subwoofer Line Out (2 x XLR & RCA Phono) 12V trigger (3.5mm jack)
Rated power consumption	20W
Dimensions	Height: 44.5mm (1.75 in) 1U Width: 483mm (19 in) Depth: 356mm (14 in)
Net weight	8kg (17.6 lb)
Finish	Front panel: Anodised Aluminium Chassis: Black



If the adjustable head unit of the CT8 LR and CT8 CC reminds you of a seashell with its inner chambers and channels, you're halfway to understanding how we preserve the driver's crystal clarity. With the distinctly conch-like Nautilus™ (left), we pioneered the concept of

draining away unwanted excess sound energy that emanates from the rear of a driver by allowing it to disappear into a tapering tube, rather than letting it bounce noisily around inside the cabinet. As the ripple tank (right) demonstrates with water, waves are virtually non-existent



## **B&W** Bowers & Wilkins

B&W Group            T +44 (0) 1903 221800  
Dale Road            F +44 (0) 1903 221801  
Worthing West Sussex    info@bwgroup.com  
BN11 2BH England    www.bwspeakers.com

B&W Group (UK Sales)  
T +44 1903 221 500  
E uksales@bwgroup.com

B&W Group North America  
T +1 978 664 2870  
E marketing@bwgroupusa.com

B&W Group Asia  
T +852 2 790 8903  
E info@bwgroup.hk

Kevlar is a registered trademark of DuPont.  
Nautilus and Matrix are trademarks of B&W Loudspeakers Ltd.  
Rohacell is a registered trademark of Röhm GMBH & Co.  
Copyright © B&W Loudspeakers Ltd. E&OE.  
Design by Thomas Manss & Company.  
B&W Loudspeakers Ltd reserve the right to amend  
details of the specifications without notice in line with  
technical developments.